

The drawings, specifications or descriptions contained herein, together with all information and know-how disclosed thereby, include technical data which is the exclusive property of Inyo Process. No disclosure to others, either in the United States or abroad, or reproduction of any part of the information supplied is to be made, and no manufacture, sale or use of any device, process or composition of matter disclosed therein, whether patented or not, shall be made except by written authorization of Inyo Process. This notice is not intended to nullify or limit rights granted by contract.

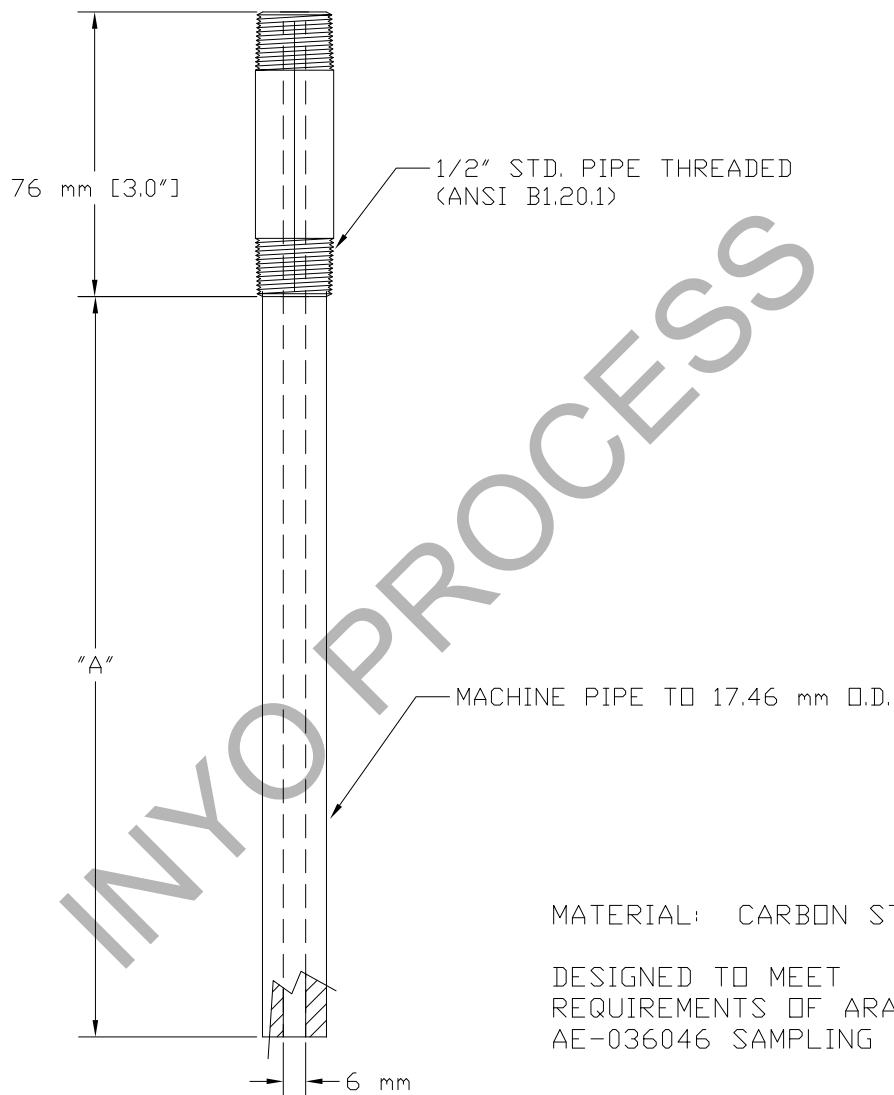

MATERIAL: CARBON STEEL  
 DESIGNED TO MEET  
 REQUIREMENTS OF ARAMCO  
 AE-036046 SAMPLING QUILLS

INYO MODEL	STC-68	STC-83	STC-95	STC-122	STC-148	STC-175	STC-200	STC-216	STC-241	STC-267	STC-292	STC-343
PIPE DIA. (in)	2"	3"	4"	6"	8"	10"	12"	14"	16"	18"	20"	24"
"A" (mm)	68	83	95	122	148	175	200	216	241	267	292	343

UNLESS OTHERWISE SPECIFIED	-		INYO PROCESS			
DIMENSIONS ARE IN INCHES DO NOT SCALE DRAWING	DRAWN	DG 12-27-11				
DIMENSIONING AND TOLERANCING PER ASME Y14.5M-1994 AND APPLICABLE STANDARDS	CHECKED	-	1/2" STANDARD SAMPLE TUBE CARBON STEEL CONSTRUCTION			
DECIMALS .XX ±.030 .XXX ±.010	DESIGN APPROVED	-				
ANGLES ±1°	MFG. APPROVED	-	SIZE	CAGE CODE	DRAWING NO	REV
SURFACE ROUGHNESS 125 ✓	QA APPROVED	-	A	-	STC-AE-036046	-
RUNOUT .010_TIR BREAK CORNERS .005-.015 INTERNAL RADII .015-.030	RELEASE DATE	-	SCALE	WEIGHT	SHEET	-